

Stacked Film Capacitor Chips

NSWC Series
(High Voltage)

FEATURES

- STACKED METALLIZED POLYETHYLENE NAPHTHALATE (PEN) FILM
- STANDARD EIA 1913, 2416 and 2420 SIZES
- HIGH HEAT AND MOISTURE RESISTANT
- VERY STABLE TEMPERATURE, FREQUENCY, VOLTAGE, BIAS AND DIELECTRIC ABSORPTION CHARACTERISTICS
- REFLOW SOLDERING ONLY
- TAPE AND REEL PACKAGING

NSWC IS
RECOMMENDED
FOR NEW DESIGNS



RoHS
Compliant

includes all homogeneous materials

*See Part Number System for Details

SPECIFICATIONS	Case Sizes		
	1913	2416	2420
Capacitance Range	0.001 ~ 0.015 μ F	0.012 ~ 0.068 μ F	0.027 ~ 0.12 μ F
Voltage Ratings	250Vdc		
Capacitance Tolerance	\pm 5%(J)		
Temperature Range	-55 $^{\circ}$ C ~ +85 $^{\circ}$ C		
Dissipation Factor	1.0% max. @ 1KHz		
Insulation Resistance (20 $^{\circ}$ C) Through 2K Ohm Resistor	3 Gigohms @ 100Vdc		
Dielectric Withstanding Voltage	150% of Rated Voltage		
Temperature Characteristic	\pm 3% Δ C Maximum Over Temperature Range		
Dielectric Absorption	0.05 ~ 0.10% Typical		

ENVIRONMENTAL CHARACTERISTICS

Life Test At +85 $^{\circ}$ C 1,000 Hours at 125% of Rated Voltage	Capacitance Change	Within \pm 1%/-6% of Initial Value
	Dissipation Factor	1.1% Maximum
	Insulation Resistance	1 Gig Ω Minimum
Resistance to Soldering Heat: +240 $^{\circ}$ C Peak	Capacitance Change	Within \pm 5% of Initial Value
	Dissipation Factor	1.1% Maximum
	Insulation Resistance	1 Gig Ω Minimum or 300 Ω /F whichever is lower
Humidity Load Life (90 ~ 95% RH) 1,000 Hours, +40 $^{\circ}$ C	Capacitance Change	(1) +8%/-5%
	Dissipation Factor	(1) \pm 1.5%
	Insulation Resistance	(1) 100Meg Ω
Resistance to Soldering Heat 240 $^{\circ}$ C for 5 seconds	Capacitance Change	Within \pm 5%
	Dissipation Factor	Maximum 1.1%
	Insulation Resistance	1Gig Ω
Solderability with 25% Wt Rosin-Methanol Flux	95% Minimum Coverage After 2.5 Second Dip into 245 $^{\circ}$ C Solder Pot	

RECOMMENDED REFLOW PROFILE

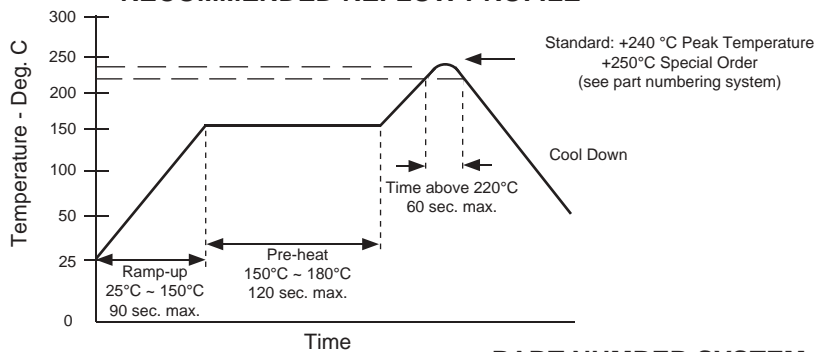

RECOMMENDED LAND PATTERN (mm)

EIA Size	A	B	C
1913	2.6	6.6	3.0
2416	3.8	7.8	3.8
2420	3.8	7.8	4.6

PART NUMBER SYSTEM

NSWC 822 J 250 TR D1 N E

- Series
- Capacitance in pF, 1st two digits are significant, 3rd digit is no. of zeros
- Tolerance Code: J= \pm 5%
- Voltage
- Tape & Reel
- Size Code
- Optional High Temp. Reflow (+250 $^{\circ}$ C)*
- RoHS Compliant

*Special packaging and handling required.



Stacked Film Capacitor Chips

NSWC Series
High Voltage

STANDARD PRODUCTS AND SIZE CODE

Cap.	Code	Working Voltage (Vdc)
		250
0.001	102	D1
0.0012	122	D1
0.0015	152	D1
0.0022	222	D1
0.0027	272	D1
0.0033	332	D1
0.0039	392	D1
0.0047	472	D1
0.0056	562	D1
0.0068	682	D1
0.0082	822	D1
0.010	103	D1
0.012	123	D1
0.015	153	D1
0.018	183	D2
0.022	223	D2
0.027	273	D3
0.033	333	D4
0.039	393	E2
0.047	473	E3
0.056	563	E4
0.068	683	E5
0.082	823	F2
0.10	104	F4
0.12	124	F5

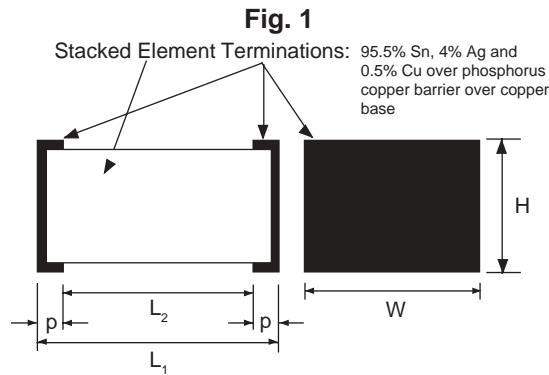

DIMENSION (mm) AND CASE CODE

Case Code	Length $L \pm 0.2$	Width W	Height $H \pm 0.3$	p	EIA Code
D1	4.8	3.3 ± 0.3	1.4	0.35 ± 0.2	1913
D2			2.0		
D3			2.4		
D4			2.8		
E2	6.0	4.1 ± 0.3	2.0		2416
E3			2.4		
E4			2.8		
E5			3.2		
F1			3.0		
F2	6.0	5.0 ± 0.4	3.2		2420
F3			3.6		
F4			3.8		
F5			4.5		

TAPE DIMENSIONS (mm)

Case Code	A ± 0.1	B ± 0.1	C ± 0.2	t	W ± 0.3	F	P ± 0.1	D $\pm 0.2/-0$	Qty/Reel
D1	3.8	5.1	2.0	0.3 ± 0.05	12.0	5.5 ± 0.05	8.0	1.5	3,000
D2			2.6						3,000
D3, D4			3.4						2,000
E1, E2	2.7	3,000							
E3, E4	3.5	2,000							
F1 ~ F5	5.5	6.3	4.7	-	1,500				

